

Technical Note

PL112 – PL140

Rectangular PICMA[®] Bender Piezo Actuators

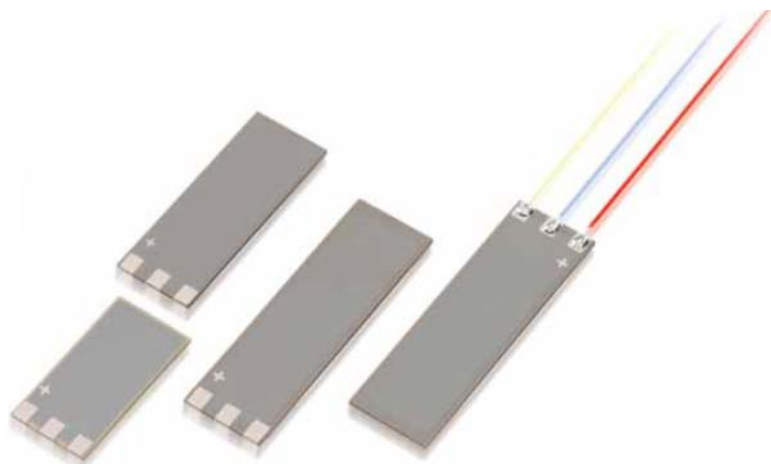

Figure 1: Different rectangular PICMA[®] bender actuator models

INFORMATION

Before soldering, installing and operating the actuator, read these descriptions and instructions carefully!

Safety

The following instructions will help you to obtain maximum performance from your actuator and avoid failures. Failure to heed warnings in this document may result in injuries (caution) or material damage (notice).

CAUTION



Risk of electric shock!

These devices require adequately trained and experienced operating personnel.

Since temperature changes and compressive stresses can induce charges in piezo actuators, even unused actuators may be a source of electric shocks.

To avoid electric shock:

- Do **not** disassemble the piezoelectric actuator.
- Make sure the bare piezoelectric actuator is discharged **before** touching it and keep the soldering pads or wires **shorted** before installation.
- Use gloves and safety glasses during handling.

NOTICE



Risk of damage from inadequate handling!

Inadequate shorting or handling may damage the actuator.

- When shorting the wires or soldering pads of a possibly charged actuator, always use a 10 kΩ current limiting resistor. Shorting a charged actuator without limiting the discharge current can fracture the PZT ceramics due to the extremely high dynamic forces caused by the rapid discharge.
- Do **not** operate the actuator at higher voltages or different polarity than stated in this document. For polarity information, see below.
- Power off the actuator immediately if you hear or see any resonant behavior. For the unloaded resonant frequency see *Technical Data*. Any resonant operation should generally be avoided. Due to self-heating effects, the specified operating temperature range of the actuator could be exceeded rapidly and irreparable damage may occur.
- Do **not** exceed the operating temperatures stated in the *Technical Data* section.
- Before operating, check whether the instructions on soldering (if applicable), installation and handling have been obeyed.
- If you use a conductive support for fixing the actuator, electrically insulate the corresponding parts of the soldering contacts.
- Do **not** drop the piezo actuator; avoid subjecting it to any kind of mechanical shock.
- Do **not** exceed the maximum load (blocking force) specified in the *Technical Data*.

NOTICE



Risk of damage from inadequate environmental conditions!

The actuator is sensitive to moisture, high relative humidity, liquids and contact with any other conductive material.

- Avoid storing or operating actuators under these environmental conditions since they can cause dielectric breakdown.
 - Ensure that moisture is as low as possible.
-

NOTICE



Risk of damage from contamination!

To avoid contamination:

- Do **not** handle the actuator with unprotected fingers.
- Always use latex or nitrile gloves. The gloves **must not** be powdered.
- Use parallel-action non-metallic tweezers to handle the actuator.
- Use isopropanol to remove contaminants.

NOTICE



Risk of damage from thermal and mechanical stress

- Be sure that the solder joint is **not** subject to “peeling” forces.
- On the actuator surface, do **not** exceed 150 °C (302 °F). Except for soldering (see below), this limitation applies to all processing steps as well as to operation. Consider that the operation of the actuator can cause heating-up.
- Do **not** file, sand or roughen the sides of the actuator.

Features

INFORMATION

Custom designs or different specifications on request.
Feel free to contact PI Ceramic GmbH!

Actuators with high reliability

Low temperature drift. Bidirectional displacements. Ceramic insulation, polymer-free. UHV-compatible to 10^{-9} hPa, no outgassing, high bakeout temperature. Reliable even under extreme conditions.

Fields of application

Research and industry, pneumatic valves, printing heads, vacuum applications. For medical technology, laser control, sensor systems, automation tasks.

Suitable drivers

E-650 piezo amplifier for multilayer bender actuators, available from PI.

Technical Note

Page 4 / 9

Product Details

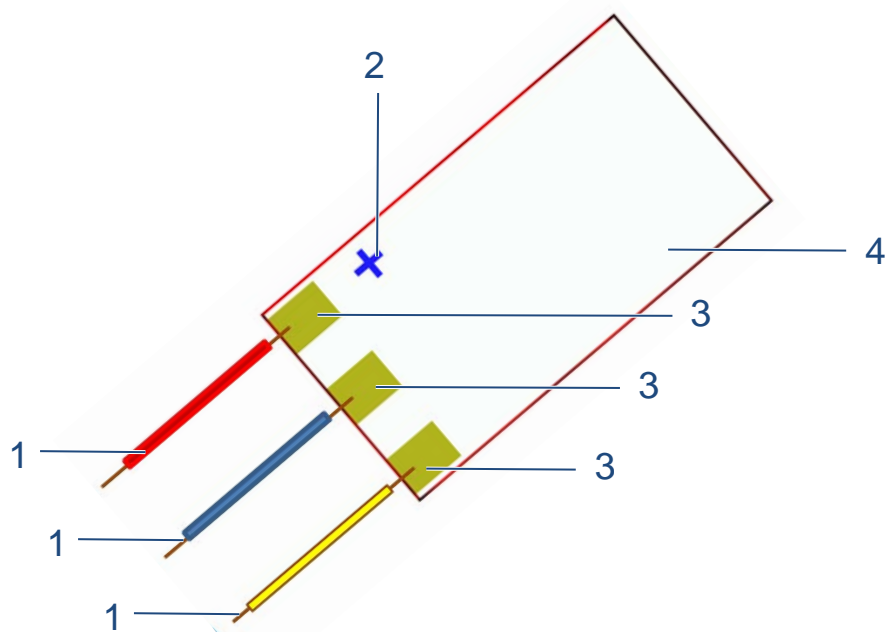

Figure 2: Details of the actuator

- 1 Wire (only with PL1xx.11 models)
- 2 Plus or dot mark indicating positive (U_+) contact position (not necessarily on the left side)
- 3 Soldering pad
- 4 Actuator body

Design and Functional Principle

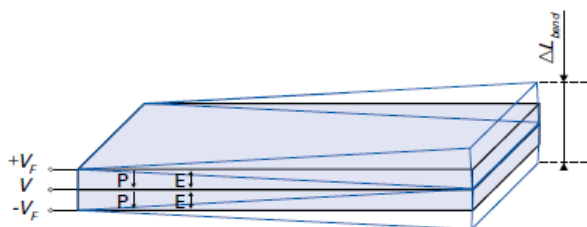

Figure 3: Displacement ΔL effected by contraction (schematic; for single-side fixation)

The actuator, shown in *Figure 3*, is built up from thin piezoceramic layers and internal electrodes. The internal electrodes extend to the rear end of the actuator and are connected to three external electrodes (called “soldering pads” in the following text). The thickness of the piezo layers expands and the length contracts if a voltage of the correct polarity is applied to the soldering pads. The bending movement (hence displacement) is caused by the contraction (“ d_{31} -effect”).

Installation

Mounting Wires / Soldering

We recommend ordering the actuator with already mounted wires (PL1xx.11). For PL1xx.10, follow the instructions below.

- The following extra materials are required for the soldering process:
 - **Solder:** lead-free, made of the system **L-Sn95..97 Ag3..4 Cu0.5..1.0**
 - **Flux:** defined as **1.1.1** or **1.1.3** accordingly to DIN EN 29454 Part 1 or defined as **ROLO** or **ROMO** according to ANSI J-STD-004
 - **Wires:** Stranded wires, ideal: AWG 32 (max. AWG 30)

Soldering wires to a PL1xx.10-type actuator

INFORMATION

The following procedure applies for each of the three wires and soldering pads intended for connection to the piezo amplifier.

1. Twist and tin the stripped end of the wire. Trim to 2 mm.



Figure 4: Wire preparation steps (schematic)

2. Apply flux to the tinned end and to the soldering pad. Hold the wire flat with its end at that point.
3. Coat the soldering tip with a small amount of solder. The soldering temperature **must not** exceed 350 °C (662 °F).
4. On the soldering pad (flat top), hold the soldering tip against the tinned end of the wire for 1 to max. 2 seconds, until the solder flows. The solder joint must be flat or hemispherical.

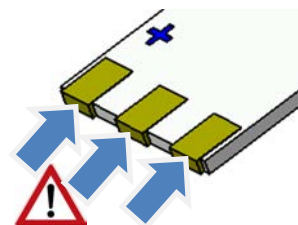
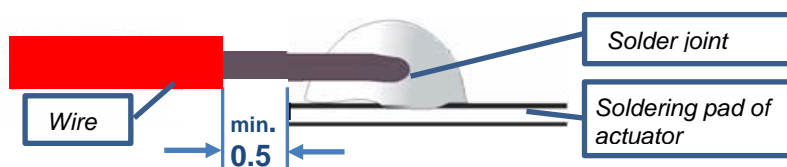

Figure 5: Left: Solder joint shape (sectional view); right: **sensitive** edges; do **not** solder here!

During long and consecutive soldering, the soldering pad can be dissolved in the melt solder. Overall soldering time has to be limited to 4 seconds.

Do **not** solder on the edge of the soldering pad (where the soldering contact is bent). Minimum distance of the wire insulation to the edge of the soldering contact should be 0.5 mm.

5. Remove flux residues in a cleaning process by applying ethanol or a higher alcohol type. Use of an ultrasonic bath is recommended.

Mechanical Installation

Single-sided fixation

For some applications, it is recommended to attach the actuator to metal or ceramic supports. This applies especially to stiffer benders with a free length L_F below 20 mm and lower displacements in applications with high inducible force and resonance frequency requests. This avoids additional drift and elastic compliance which could occur with soft polymer materials. Supports are not included in the delivery.

Epoxy adhesives are recommended for mechanical assembling. The curing temperature should be as low as possible to reduce thermo-mechanical stress in the support.

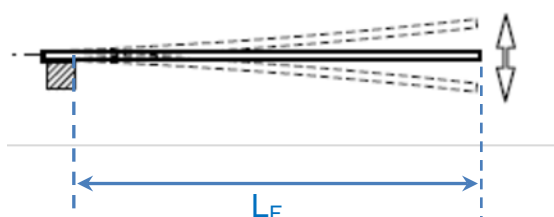

Figure 6: Actuator in a single-sided configuration with free length L_F

The actuator is mostly assembled in a single-sided (“cantilever”) configuration.

When fixing the actuator, note that the specified free length L_F has to be maintained to achieve the nominal values for the displacement as well as for the blocking force. Mounting it with a reduced free length would reduce the displacement in a square relation and increase the blocking force in a linear relation.

We recommend fixation with an epoxy adhesive and according to the figure above. Alternative mounting techniques include gluing the bender into a slot, clamping it between two soft layers or at least one soft layer and one stiff layer or using an injection molding technique. These alternative configurations have to be tested comprehensively before the actuator is used for serial production. Clamping pressures should be as low as possible for the mechanical stability of the assembly.

Two-sided fixation

The actuators can also be mounted with two-sided fixation (see figure below). This assembly results in four times higher induced force as well as four times lower displacement for the same bender at the same free length compared to the single-sided fixation.

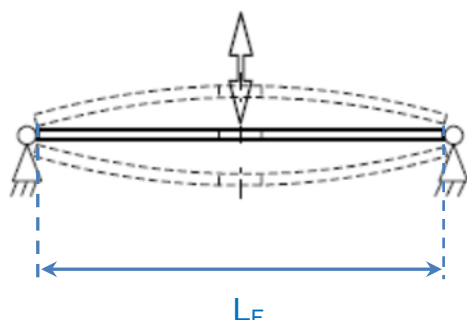

Figure 7: Actuator with two-sided fixation by rotational supports (clamps), with central output and free length L_F

A central output can be realized by gluing a metal or ceramic part to the actuator. The assembly can be supported by a central hole which is not included in the standard product. A low-curing two-component standard epoxy adhesive is recommended.

Technical Note

Page 7 / 9

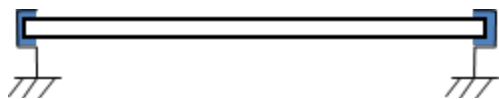

Figure 8: Metal flex configuration

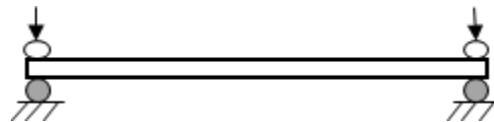

Figure 9: Soft/stiff-combination cylinder assembly

Figure 8 and Figure 9 show two possible configurations for the assembly at the two outer sides of the actuator. For longer models with free length above 20 mm, it may be necessary to consider not only the rotational but also the lateral softness because the bender contracts laterally during operation.

The mounting shown in Figure 8 comprises folded metal clamps which are axially stiff and glued to the bender with an insulating epoxy adhesive. The pivot point of the metal flexes should be as close to the bender as possible. In Figure 9, a soft polymer cylinder presses the bender against stiffer rotatable metal or ceramic cylinders beneath the actuator.

These mounting types have to be comprehensively tested before application in serial production, especially for clamped assemblies. The soldering pads have to be appropriately insulated from the mounting.

Electric Connection

INFORMATION

We recommend using the *E-650* piezo amplifier available from PI.

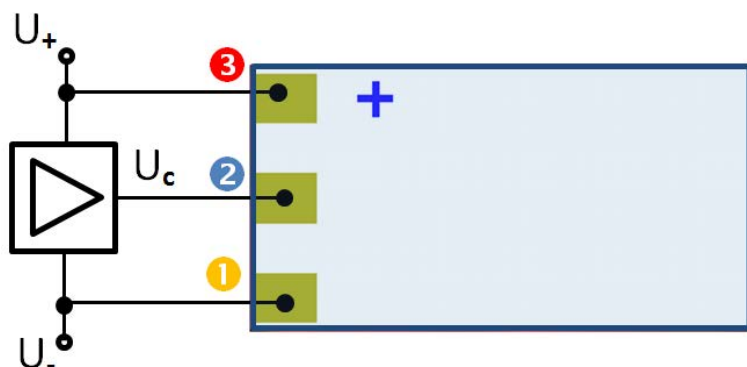

Figure 10: Electric connection scheme with

(1) – (3) Soldering pads No.1, 2, 3 (and for PL1xx.11: related wires)

See Figure 10: In relation to the dot or “plus” mark, the nearest soldering pad No. 3 (or red wire respectively, if a PL1xx.11 model is used) must be connected to U_+ and the most distant soldering pad No. 1 (or yellow wire for PL1xx.11) has to be attached to U_- respectively. Soldering pad No. 2 (or blue wire for PL1xx.11) is intended for connection to the control voltage U_c generated by the piezo amplifier.

Operation

NOTICE



Improper polarity and voltage can destroy the actuator.

- Do **not** reverse polarity.
- Between soldering pads / wires No. 3 and 1 and for U_c : Do **not** exceed 60 V. See *Figure 10*.

Controlling the Displacement via Applied Voltages

Single voltage control

If a voltage is applied between two soldering pads, the actuator bends in one direction only (example: for PL127.10 with 60 V and single-sided fixation, a displacement of max. 450 μm is reached at the end opposite to the fixation. The active piezo layers contract in length, and the other layers become passive (no shape change).

Full differential-voltage control (recommended)

Based on the **full differential-voltage control** (see *Figure 10*), bending can be controlled over the full range in both directions.

Operating options

Regarding the voltages, the options shown in the table below apply.

Soldering contact / wire no. (according to <i>Figure 10</i>)	1	2	3
Voltage designation	U_-	U_c	U_+
Option 1	GND	0 V to 60 V	60 V
Option 2	-30 V	-30 V to 30 V	30 V

Displacement direction

If the soldering pads of the bender point to the top and the bender is driven with a positive voltage at contact no. 3 and 2 and GND at contact no. 1, its free end bends to the top for single sided fixation, or its center bends to the bottom for two-sided fixation, respectively.

Storage

Store the components in a dry place (non-condensing) at room temperature.

Technical Note

Dimensions

For the type-specific values, see *Technical Data* below. Tolerance values in mm.

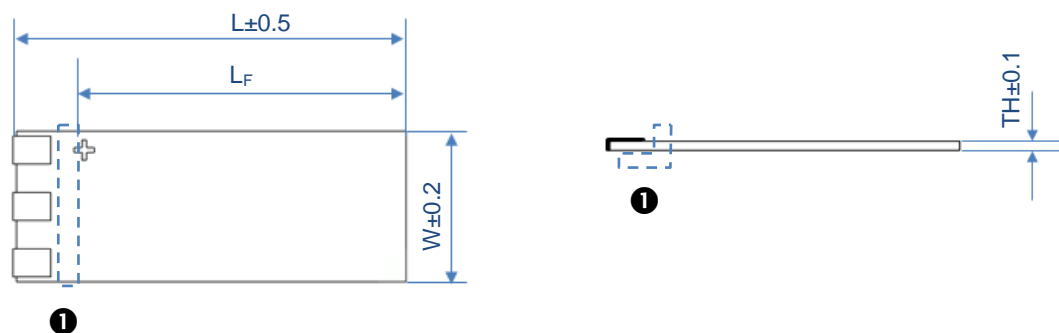

Figure 11: Dimension designations of the **PL1xx** with
 (1) Recommended position of a support for single-sided fixation (“clamping”; see dashed lines; support is not included in the delivery)

Technical Data

	PL112.10 PL112.11*	PL122.10 PL122.11*	PL127.10 PL127.11*	PL128.10 PL128.11*	PL140.10 PL140.11*	Unit	Tolerance
Operating voltage**	0 to 60 or -30 to 30	0 to 60 or -30 to 30	0 to 60 or -30 to 30	0 to 60 or -30 to 30	0 to 60 or -30 to 30	V	
Displacement	<i>±80</i>	<i>±250</i>	<i>±450</i>	<i>±450</i>	<i>±1000</i>	µm	±20%
Free length L _F	12	22	27	28	40	mm	
Dimensions L x W x TH	18.0 x 9.6 x 0.65	25.0 x 9.6 x 0.65	31.0 x 9.6 x 0.65	36.0 x 6.3 x 0.75	45.0 x 11.0 x 0.6	mm ³	(see. abv.)
Blocking force	<i>±2.0</i>	<i>±1.1</i>	<i>±1.0</i>	<i>±0.5</i>	<i>±0.5</i>	N	±20%
Electrical capacitance***	2 * 1.1	2 * 2.4	2 * 3.4	2 * 1.2	2 * 4.0	µF	±20%
Resonant frequency****	<i>2000</i>	<i>660</i>	<i>380</i>	<i>360</i>	<i>160</i>	Hz	±20%
Operating temperature	-20 to 150	-20 to 85	-20 to 85	-20 to 150	-20 to 85	°C	
Piezo ceramic type	PIC252	PIC 251	PIC 251	PIC252	PIC 251		

* comes with mounted 100 mm PTFE-insulated wires, AWG 32 (Ø 0.49 mm)

** depending on electric connection option, see above

*** at U_{pp} = 1 V (differential peak voltage), 1 kHz, 20 °C

**** at U_{pp} = 1 V, without mass load

Note: Specifications may vary depending on the actual clamping / mounting conditions and on the applied mechanical load. Values in *italics* **only** applicable for **single-sided** mounting with free length L_F!